

State of Maryland
Interagency Commission on School
Construction
Business Management System
State Rated Capacity
Process User Guide



Interagency Commission on School Construction
351 W. Camden Street
Baltimore, MD 21201
(410) 767-0617

This guide is available for download at iac.mdschoolconstruction.org

State Rated Capacity Process

Purpose of Process

To submit a request to establish or update the State Rated Capacity for a facility. Calculation of the official approved State Rated Capacity will be determined by IAC staff in accordance with COMAR 14.39.02.05

Starting the Process

To start this process, you must choose the LEA Global Project. Once you are within that project, please use these steps to start the process.

1. In the Project Menu on the left side of the page, select the "Processes" tab.
2. In the "Project Processes" home screen, click on the "Start process" button which is situated in the top right corner of the page.



3. Once you have clicked the "Start Process" button, you will be presented with a list of processes that you have access to start or submit.
4. Choose the process by clicking on the name.

Select process ×

🔍 State Rated Capacity (SRC) ×

To request a variance to the Gross Area Baseline (GAB) for a school facility.

Healthy School Facility Fund (HSFF)
To request school construction funding from the Healthy School Facility Fund (HSFF).

Invoice/Reimbursement Request (INV)
To request payment of awarded school construction project funds.

Project Closeout (PC)
To complete the final financial closeout of a school construction project.

Site Review Process (SRP)

Standard Operating Invoice (SOI)

✓ **State Rated Capacity (SRC)**

↓ Download SRC Start SRC

5. You will then be presented with the initial step of the process. Please review all data fields and make sure that you include all required information and documents. The school for which the SRC is being updated will be identified at the fields at the top of the Facility Information section for School Name and PSC No.

Initial Submission Layout

Your initial step will require you to determine information that is important to the request. Please be sure to read each data field description carefully, and load all necessary information. This will include both comments and important documents.

State Rated Capacity (SRC)

Start Process

Project: *Washington/Governor/ Mickey Memorial/ Overpass/ Project (0,014455669882211)
Project Number: CFS-1234
Process: State Rated Capacity

Print Check Spelling **Submit** Save Draft Cancel

Details Documents (0) Attached Processes (0) Attached Forms (0)

Expand All Collapse All

Type of Room

PreK/Head Start/EEP: Enter the number of rooms:

Kindergarten:

Regular (Elem):

Special Ed:

Regular (sec): Regular, Excluding Physical Education

Career Tech:

Alternative Rooms:

Physical Education (sec): Typical high school gymnasiums are designed to hold two full-size cross-court basketball courts which overlap the main court. They frequently are provided with a divider curtain that divides the room into two separate spaces when the main competition basketball court is not in use. These gymnasiums are typically around 10,000 net square feet and have previously been calculated as four teaching stations. This type of gymnasium is limited to two teaching stations. In the rare circumstance that a larger gymnasium exists that can accommodate three cross-court basketball courts and is provided with two dividing curtains or other partitions, it is counted as three teaching stations. The minimum size of a gymnasium is 13,000 net before it will be considered to count as three teaching stations. Additionally, because high schools' educational programs often include fitness centers or weight rooms with extensive heavy fixed equipment that make the space unusable for any other purpose, an LEA may request one such space with a maximum size of 2,500 net square feet can be included within a high school program and not counted as a teaching station. LEAs will submit equipment plans of the space being requested to meet this criteria for review by IAC staff.

Fitness Center (Photo/Floorplan): (Optional) An LEA may request one such space with a maximum size of 2,500 net square feet can be included within a high school program and not counted as a teaching station. LEAs will submit equipment plans of the space being requested to meet this criteria for review by IAC staff. Submit supporting documentation here.

Required Attachments (Uploads)

Reason for Update / Additional Info/Reason for Update / Additional Info:

Room inventory table or spreadsheet:

Color keyed floor plan of the facility with room uses:

Print Check Spelling Submit Save Draft Cancel

Once you have completed all required fields, click submit in the right hand corner of the submission page.

The process will then be routed to the appropriate next step. You are able to follow the process as it goes through all steps by clicking the process instance with the Processes tab within the project.

IAC Project Processes *Washington/Governor/ Mickey Memorial/ Overpass/ Project (0,014455...)

Unfinished Drafts | Import Processes

Start SRC Start process

Filters

PROCESSES REPORTS

Instan...	State	Subject	Step	In Step Since	Date Due	Status	Requested Comment
SRC - 10	Open	test of private doc	IAC Planning Completeness Check	Jun 4, 2024		Submitted	
SRC - 13	Open	Washington' State Rated Capacity08/09/2024	IAC Planner Review	Aug 9, 2024		Submitted	

Page View 100 Showing result 1 - 2 of 2

Process Workflow

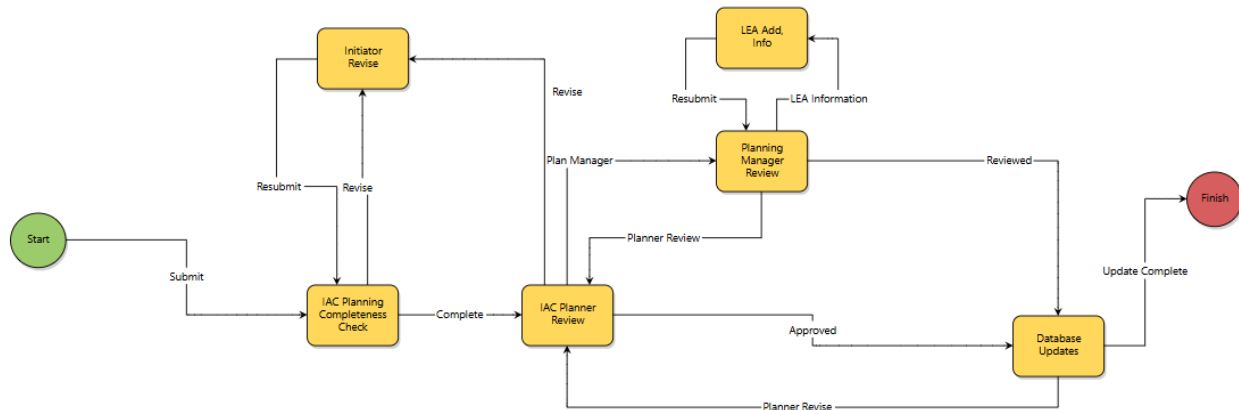

Workflow Steps

1. **Start:** Requested by the LEA Facilities Planner. The LEA Facilities Planner will complete all required fields by adding pertinent data, and required documents.
2. **IAC Planning Completeness Check:** The IAC Planning Administrator will review the request for completeness. If the Planning Administrator has any questions or requests, the request will be sent back to the process initiator with comments.
3. **IAC Planner Review:** The IAC Planner will then review the request and any comments. If the IAC Planner has any questions or requests, the request will be sent back to the process initiator with comments.
4. **IAC Planning Manager Review:** The IAC Planning Manager will do a final review if needed. If there are any questions, then the request will be sent back to the process initiator for updates. If there are no questions, then the Manager will route the process to the Database Manager.
5. **Database Manager:** Once approved by the IAC Planner or IAC Planning Manager, the IAC Database Manager will update the facility record with any new information. Once complete, the Database Manager will then complete the process.